

Features:

- n Isolated mounting base 3000V~
- n Pressure contact technology with Increased power cycling capability
- n Space and weight saving

Typical Applications:

- n Various rectifiers
- n DC supply for PWM inverter

| V _{RRM} | Type & Outline |
|------------------|-----------------|
| 2000V | MDx800-20-411F3 |
| 2200V | MDx800-22-411F3 |
| 2500V | MDx800-25-411F3 |
| 2500V | MD800-25-411F3G |

MDx stands for any type of **MDC, MDA, MDK**

| SYMBOL | CHARACTERISTIC | TEST CONDITIONS | T _j (°C) | VALUE | | | UNIT |
|----------------------|--|--|---------------------|-------|------|-------|----------------------------------|
| | | | | Min | Type | Max | |
| I _{F(AV)} | Mean forward current | 180° half sine wave 50Hz Single side cooled, T _C =60°C | 150 | | | 800 | A |
| I _{F(RMS)} | RMS forward current | | | | | 1256 | A |
| I _{RRM} | Repetitive peak current | at V _{RRM} | 150 | | | 45 | mA |
| I _{FSM} | Surge forward current | V _R =60%V _{RRM} , t=10ms half sine, | 150 | | | 18.0 | kA |
| I ² t | I ² t for fusing coordination | | | | | 1620 | 10 ³ A ² s |
| V _{FO} | Threshold voltage | | 150 | | | 0.88 | V |
| r _F | Forward slope resistance | | | | | 0.30 | mΩ |
| V _{FM} | Peak forward voltage | I _{FM} =2400A | 25 | | | 1.75 | V |
| R _{th(j-c)} | Thermal resistance Junction to case | Single side cooled per chip | | | | 0.075 | °C/W |
| R _{th(c-h)} | Thermal resistance case to heatsink | Single side cooled per chip | | | | 0.024 | °C/W |
| V _{iso} | Isolation voltage | 50Hz, R.M.S, t=1min, I _{iso} : 1mA(MAX) | | 3000 | | | V |
| F _m | Terminal connection torque(M12) | | | 12 | | 16 | N·m |
| | Mounting torque(M8) | | | 10 | | 12 | N·m |
| T _{vj} | Junction temperature | | | -40 | | 150 | °C |
| T _{stg} | Stored temperature | | | -40 | | 125 | °C |
| W _t | Weight | | | | 3230 | | g |
| Outline | 411F3 | | | | | | |

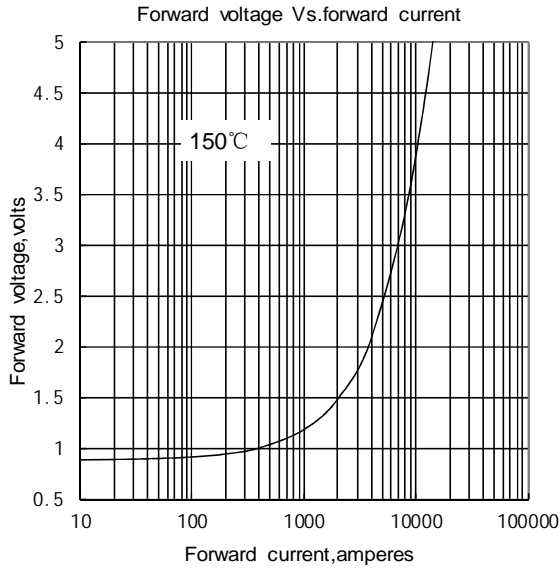

Fig.1

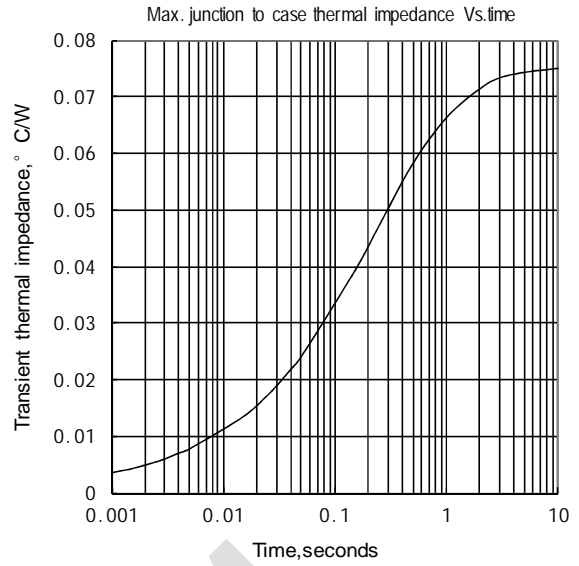

Fig.2

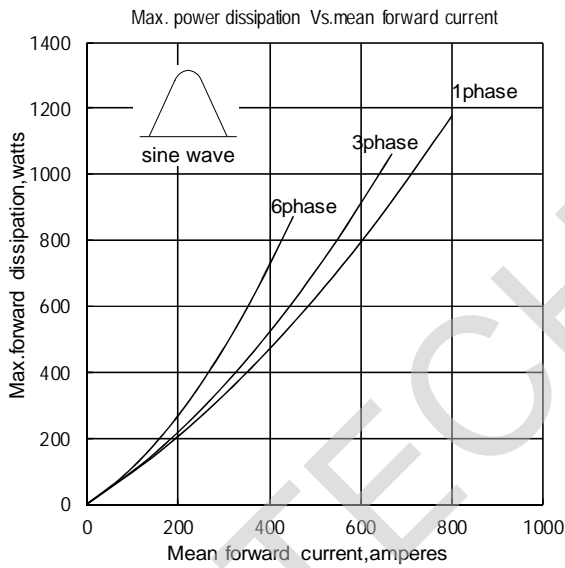

Fig.3

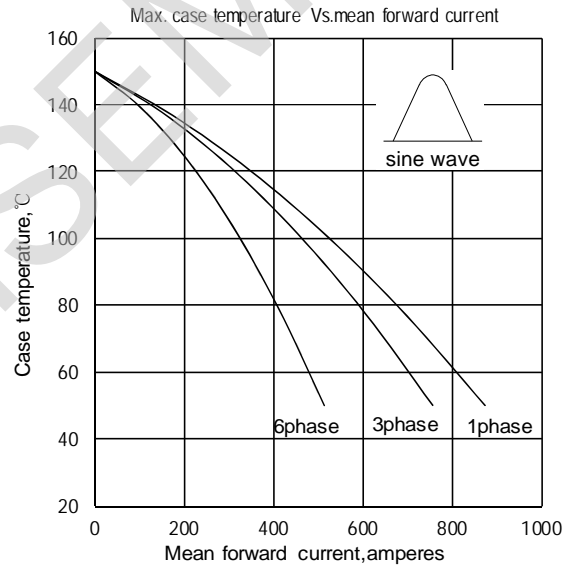

Fig.4

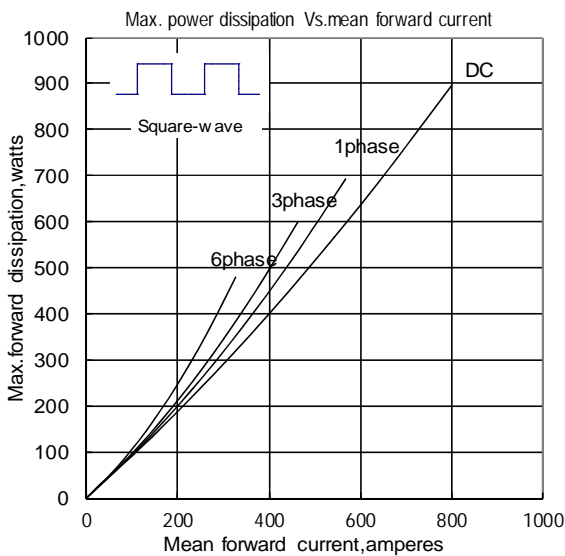

Fig.5

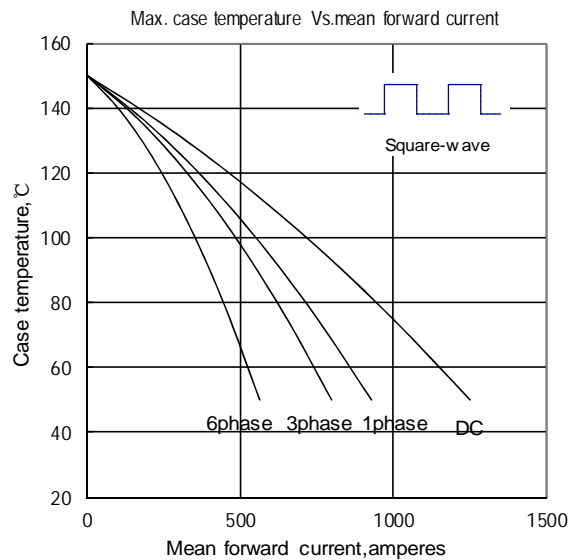

Fig.6

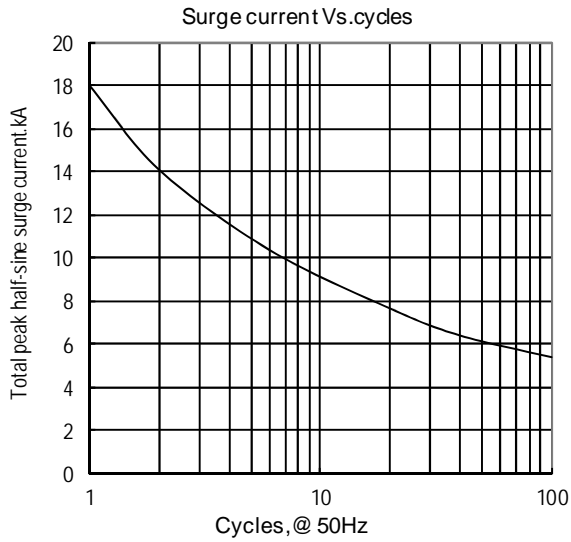

Fig.7

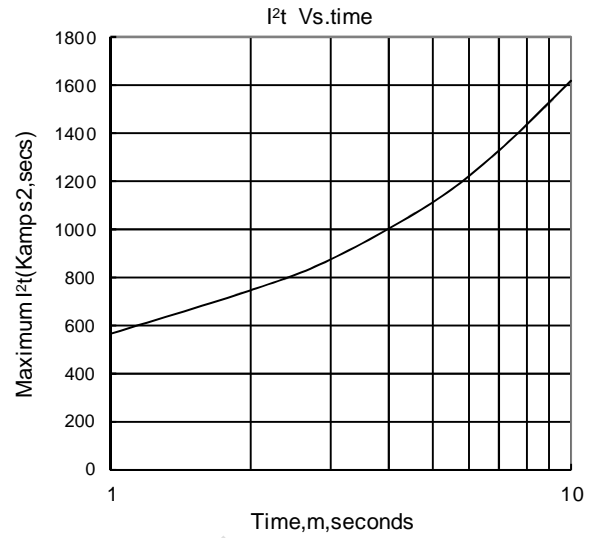
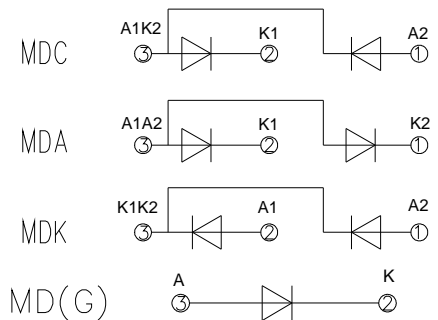
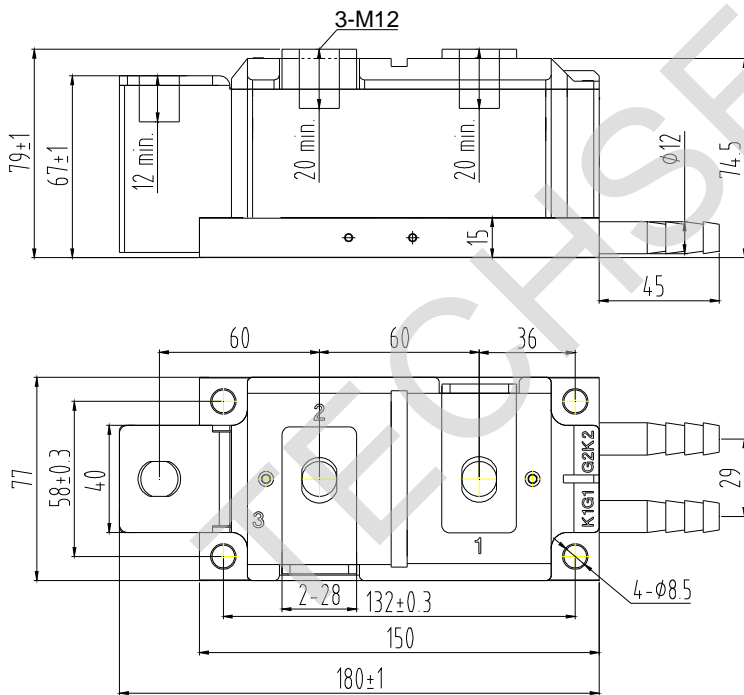

Fig.8

Outline:



Unmarked dimensional tolerance: ±0.5mm